

# ALUMINUM TREADPLATE CORNER PROTECTOR - TPCG-60

APPROX WEIGHT: 12.72 lbs.  
 DOES NOT INCLUDE WEIGHT OF POWER OR PACKAGING!!!

\*\*\* ANY ADDITIONS, DELETIONS, OR OMISSIONS MUST BE CORRECTED ON THIS DRAWING AS THIS DRAWING WILL BE CONSIDERED ALL INCLUSIVE \*\*\*

ALL GRAPHICS PROVIDED ARE FOR REFERENCE ONLY. IF CERTAIN DIMENSIONS ARE CRITICAL PLEASE VERIFY THOSE DIMENSIONS WITH YOUR SALESPERSON

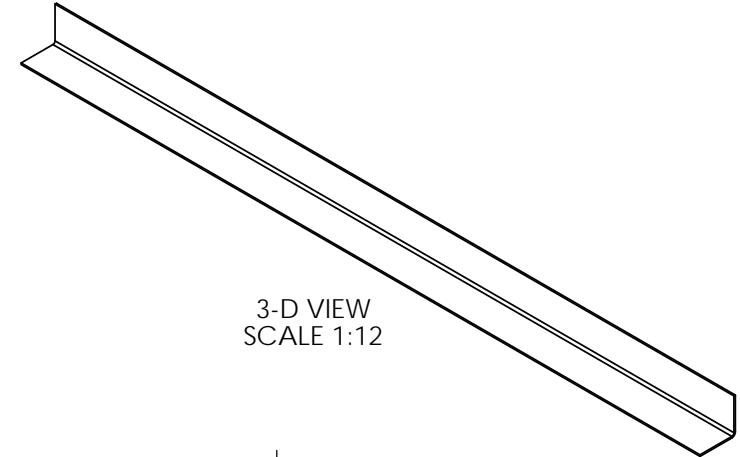

3-D VIEW  
 SCALE 1:12

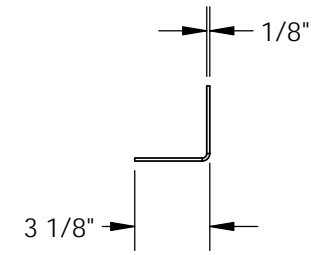
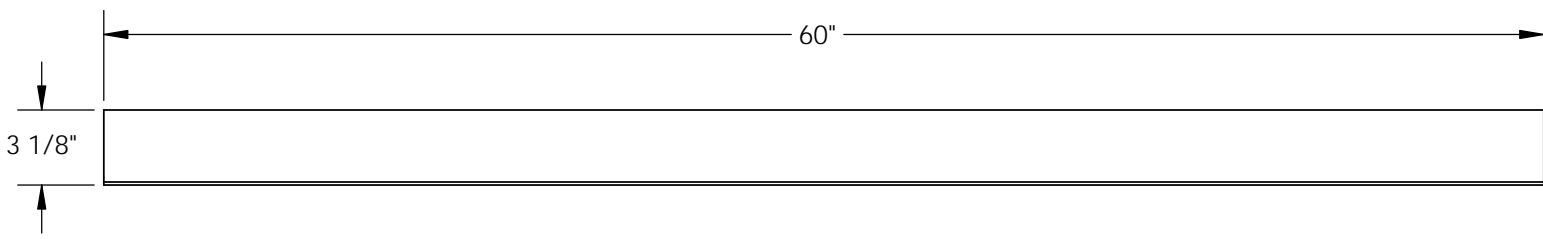

## STANDARD FEATURES

- MODEL NUMBER IS TPCG-60
- OVERALL WIDTH IS 3 1/8"
- OVERALL LENGTH IS 60"
- OVERALL HEIGHT IS 3 1/8"
- TREADPLATE THICKNESS IS 1/8"
- \*\*HARDWARE AND ADHESIVE NOT INCLUDED

## SPECIAL FEATURES

NONE

DIMENSION TOLERANCE  $\pm 1/4"$

<b>A P P R O V A L</b>	I, THE UNDERSIGNED, AGREE THAT THE PRODUCT AS REPRESENTED SATISFIES DESIGN AND DIMENSION REQUIREMENTS. I ALSO ACKNOWLEDGE MY DUTY TO CONFIRM PRODUCT AND INSTALLATION COMPLIANCE WITH ALL APPLICABLE FEDERAL, STATE AND LOCAL REGULATIONS AND STANDARDS.	
	<b>ALL SPECIAL UNITS ARE NON-RETURNABLE</b>	
	[ ] As drawn      [ ] As marked	
Signed: _____		Date: _____
<b>LEAD TIME WILL START UPON RECEIPT OF SIGNED APPROVAL DRAWING</b>		

FOR INTERNAL USE ONLY PROJECT SIGN OFF	
SALES	
ENG.	
FAB.	
POWER	

DISTRIBUTOR'S NAME:		P.O.#
VESTIL MANUFACTURING		X
DRAWN BY:	DATE:	W.O.#
W.BURKHART	07/09/15	X
REFERENCE:	SCALE:	SALES:
X	1:8	X
QUOTED LEAD TIME:	QUOTE #	FILE NAME:
X	X	29-007-295